

HYUNDAI WIA
High Precision 5-axis Vertical Machining Center

KF-5A Series

KF3500/5A | KF7300/5A



Technical Leader

The Vertical Machining Center KF-5A Series designed by Hyundai WIA with years of expertise and the latest technology, ensures performance requirements of the mold industry.

In addition, KF-5A Series can process products of various shapes with 5-axis table design.

		KF3500/5A	KF7300/5A
Table Size (L×W)	mm(in)	Ø350 (Ø13.8")	Ø730 (Ø28.7") [Ø630 (Ø24.8")]
Max. Load Capacity	kg(lb)	250 (551) - Max. Inertia : 2.09 kg.m ²	500 (1,102)
Sp. Taper	-	BBT40	BBT40 [HSK-A63]
Sp. Speed	r/min	12,000 [15,000] [20,000]	12,000 [20,000]
Sp. Power (Max./Cont.)	kW(HP)	18.5/11 (25/15) [18.5/11 (25/15)] [22/18.5 (29.5/25)]	22/18.5 (29.5/25) [22/18.5 (29.5/25)]
No. of Tools	EA	30 [40, 60]	40 [60]
Travel (X/Y/Z)	mm(in)	400{+200}/655/500 (15.7" {+7.9"}/25.8"/19.7")	765/650/520 (29.5"/25.6"/20.5")
Rapid Traverse Rate	m/min	36/36/30	40/40/40

[] : Option

KF-5A Series

Best Performance in the Class & 5-axis Machining

- 5-axis table to satisfy various machining needs
- Column moving structure for automation system (KF7300/5A)
- High speed built-in spindle for the utmost quality machining
- All axis roller type LM guide for high speed & rigidity
- Improved user convenience by applying the latest controller of FANUC



01 KF3500/5A

Super Quality & productivity 5-axis Vertical Machining Center

ATC & Magazine

- No. of Tools : 30 [40, 60] EA
- Max. Tool Length : 270 mm (10.6")
- Max. Tool Dia. (W.T/W.O)
30T : $\varnothing 80/\varnothing 125$ mm ($\varnothing 3.1"/\varnothing 4.9"$)
40, 60T : $\varnothing 76/\varnothing 125$ mm ($\varnothing 3"/\varnothing 4.9"$)

High Precision Spindle

- Direct Spindle : 12,000 [15,000] r/min
- Built-in Spindle : [20,000] r/min
- Hydraulic Tool Lock Method
- Tool Shank : BBT40

5-axis Table

- Table Size : $\varnothing 350$ mm ($\varnothing 13.8"$)
- Max. Load Capa. : 250 kg (551 lb)
- Driving Method : Roller Gear Cam

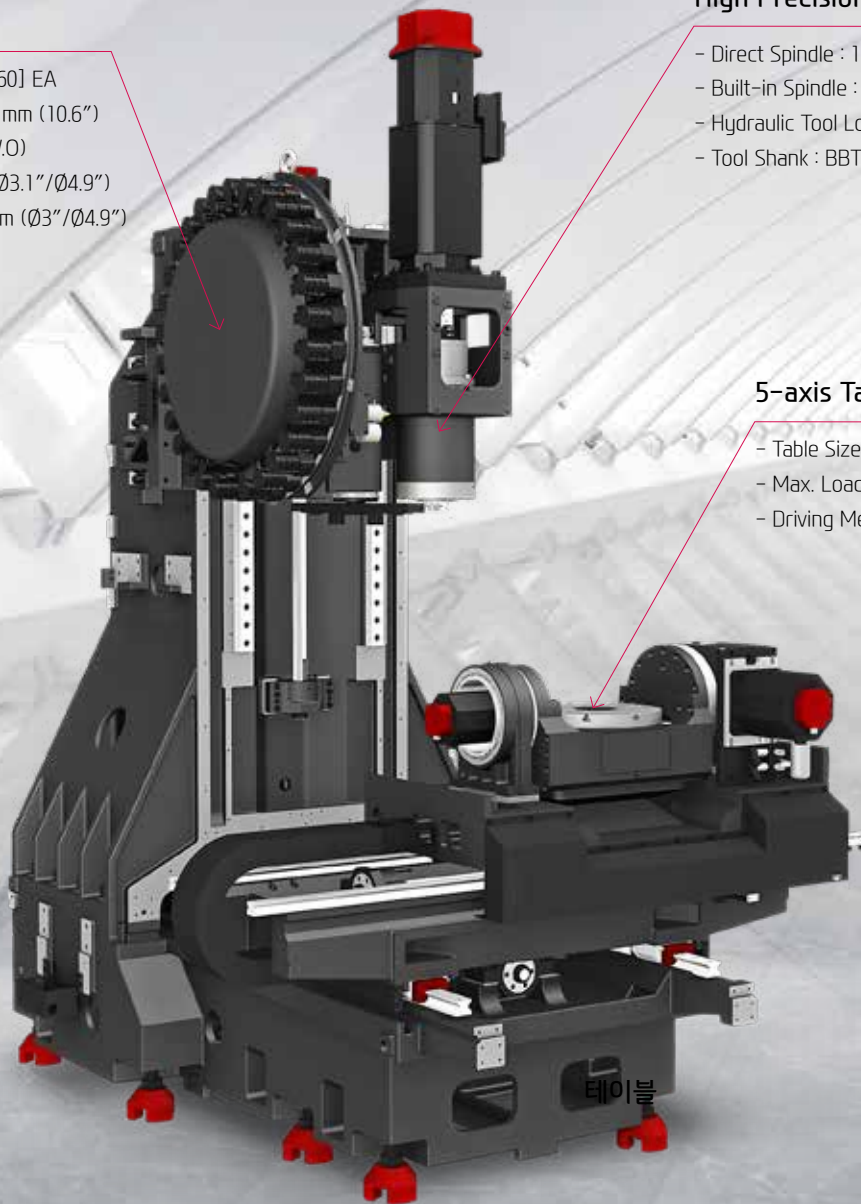

HIGH PRECISION & HIGH SPEED

HIGH-PRECISION STRUCTURE

Optimal Structural Analysis

KF3500/5A is designed to have optimal structure through Hyundai WIA's unique structural analysis.

In particular, enhancement of bed and column's rigidity makes excellent performance even in heavy duty cutting.

Optimization of Installation Area

Installation is convenient even in small spaces with compact size of 6.5m 2 and it improves space efficiency for the factory of customers.

Floor Space (L×W) **3,255×1,900** mm (128.1"×74.8")

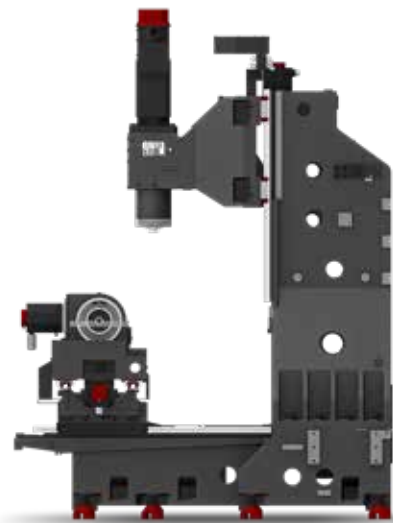

KF-5A Series
Vertical Machining Center

04
+
05

GUIDE WAY

High-Speed Roller LM Guideway

By applying an roller LM guide structure with high speed and rigidity, rapid traverse rate of **36m/min** is achieved based on the X/Y axis.

Ball Screw

The pretensioned ball screw minimizes the expansion and contraction according to the heat and further reinforces the rigidity by the double anchor support method.

<3 Row bearing / Z-axis ball screw : + Oil + Air Lubricated>

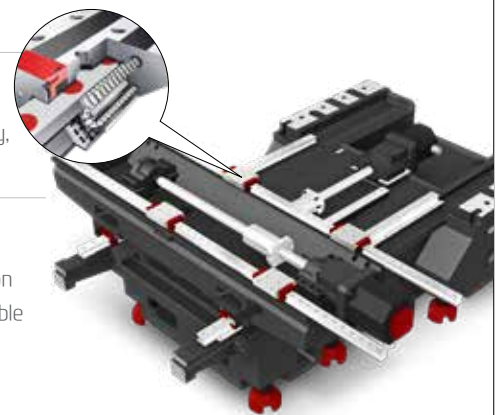

CREATING VALUE
IN SEAMLESS MOBILITY

Rapid Traverse Rate (X/Y/Z) (A/C)	Travel (X/Y/Z)
36/36/30 m/min 30/40 rpm	400{+200}/655/500 mm (15.7" {+7.9"}/25.8"/19.7")

❖ Very outstanding A/C axis rotation speed with application of roller gear cam

HIGH PRECISION SPINDLE

Excellent machining performance with high-precision spindle

KF3500/5A Spindle Specifications

[] : Option

Speed r/min	Motor (Max./Cont.)	Torque (Max./Cont.)	Driving Method
12,000 rpm	18.5/11 kW (25/15 HP)	118/52.5 N·m (87/38.7 lbf·ft)	Direct
[15,000 rpm]	[18.5/11 kW (25/15 HP)]	[118/52.5 N·m] (87/38.7 lbf·ft)	
[20,000 rpm]	[22/18.5 kW (29.5/25 HP)]	[119.7/63 N·m] (72.3/59 lbf·ft)	Built-in

KF3500/5A Table Specifications

Table Size	Max. Load Capacity	Slope Angle	Rotation Angle	Min. Indexing Angle	Driving Method
Ø350 mm (Ø13.8")	250 kg (551 lb)	+30° ~ -120°	360°	0.001°	Roller Gear Cam

HIGH-PERFORMANCE SPINDLE & TABLE

SPINDLE

Direct Driven Spindle

The directly coupled spindle at a maximum revolution of 12,000rpm [Opt. 15,000rpm], allows high-speed processing. Additionally, the large diameter and the thickness of the spindle add to the stability of the machine.

Built-in Spindle **OPTION**

The built-in spindle minimizes spindle vibration, enabling outstanding performance in a high-precision cutting environment such as complex shaped work-piece.

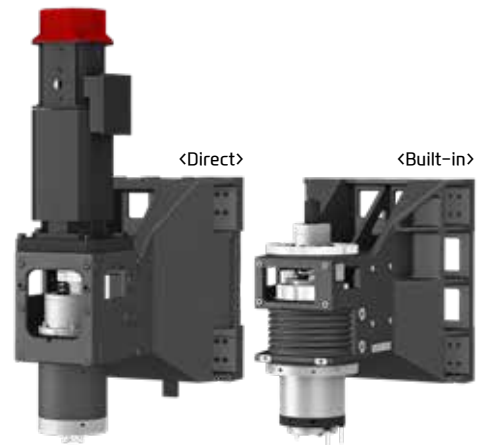

Through Spindle Coolant (20/30/70 bar) **OPTION**

Through Spindle Coolant is exceedingly useful when drilling deep holes. It helps increase the lifetime of the tool, while decreasing cycle time.

Dual Contact Spindle

The Big Plus spindle system (BBT40) provides dual contact between the spindle face and the flange face of the tool holder.

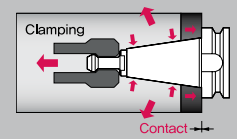

TABLE

5-axis Tilting Rotary Table

The 5-axis tilting rotary table allows users to produce a wide range of complicated work pieces. The 'C' axis has full 360° rotation and the 'A' axis has 150° rotation.

<B/C axis rotary scale standard application>

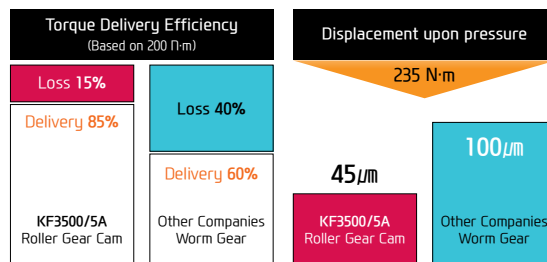

Roller Gear Cam

KF3500/5A developed with application of accumulative know-how and new technology of Hyundai Wia is a next-generation machining center featuring optimal performance in complex form machining. Also, it has superb precision and durability while also being excellent for 5-axis machining with less power loss even at high-speed rotation.

❖ Superior power delivery efficiency and strength compared to worm gear table of other companies

02 KF7300/5A

Super Quality & productivity 5-axis Vertical Machining Center

ATC & Magazine

- No. of Tools : 40 [60] EA
- Max. Tool Length : 300 mm (11.8")
- Max. Tool Dia. (W.T/W.O)
40T : $\varnothing 76/\varnothing 125$ mm ($\varnothing 3"/\varnothing 4.9"$)
60T : $\varnothing 75/\varnothing 127$ mm ($\varnothing 3"/\varnothing 5"$)

5-axis Table

- Table Size
 $\varnothing 730$ mm ($\varnothing 28.7"$) [$\varnothing 630$ mm ($\varnothing 24.8"$)]
- Max. Load Capa. : 500 kg (1,102)
- Driving Method : Gear

High Precision Spindle

- Built-in Spindle
- 12,000 r/min [20,000 r/min]
- Y-axis Ram Type
- Tool Shank : BBT40

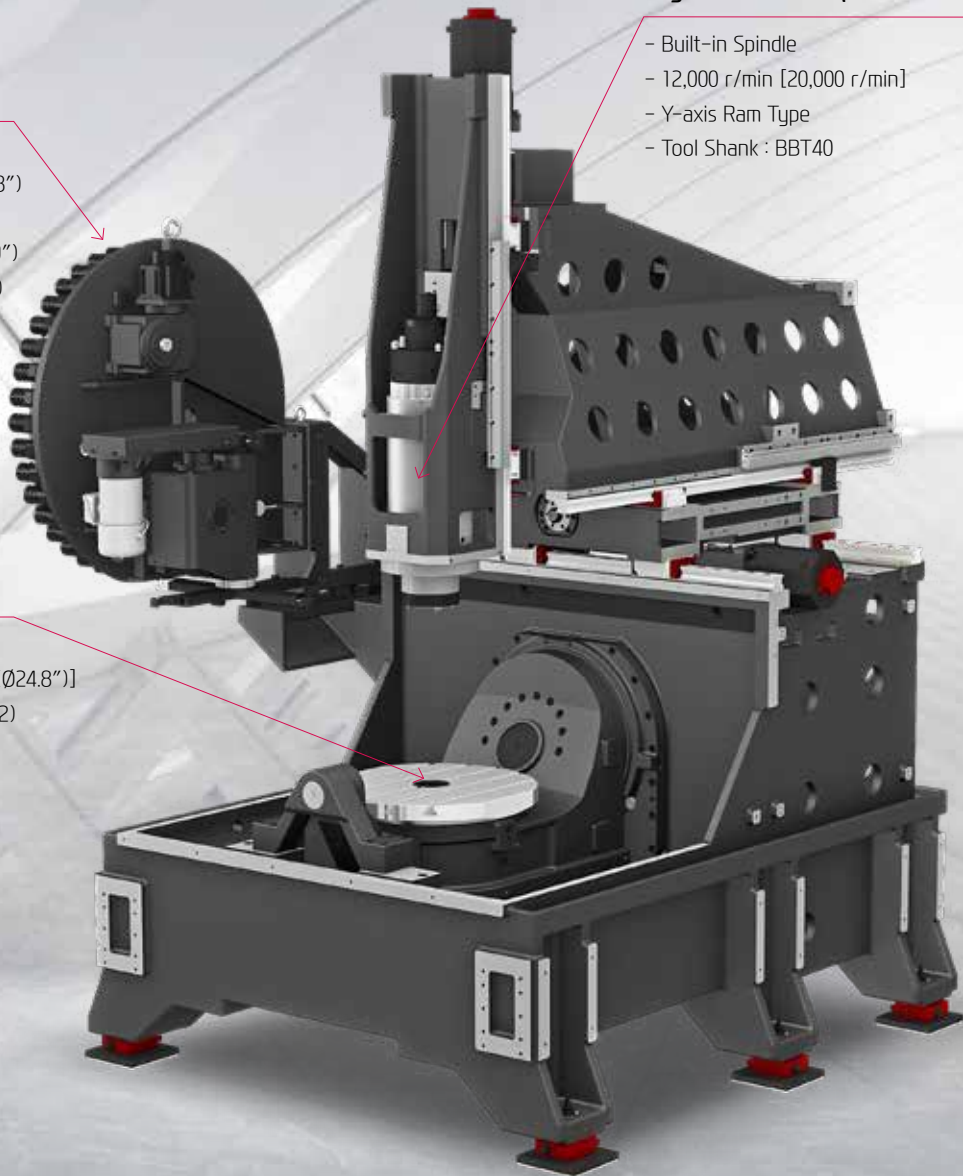

HIGH PRECISION & HIGH SPEED

HIGH-PRECISION STRUCTURE

Wall Type Structure

The structure of KF7300/5A is a wall type for high-precision machining. In particular, the feed is separated from the table to maintain high-precision machining even in heavy work.

Optimization of Installation Area

Installation is convenient even in small spaces with compact size of 10.1m² and it improves space efficiency for the factory of customers.

Floor Space (L×W) 3,050×3,300 mm (120.1"×129.9")

Direct Chip Discharge Structure

The structure was designed for the chip to fall directly to the lower part of the bed to improve chip discharge capability, and the high-temperature chips and coolant are discharged immediately without accumulating on the bed, minimizing thermal deformation of the structure.

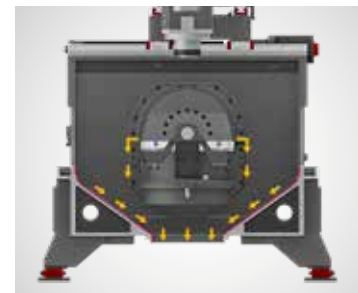
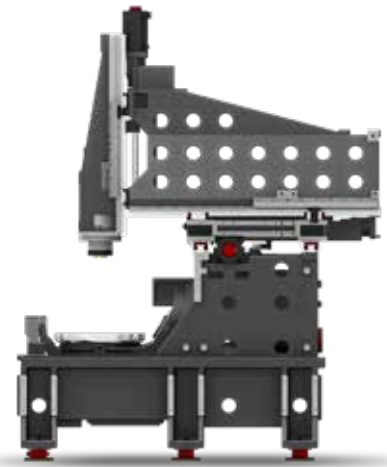

GUIDE WAY

Roller Type LM Guideway

For processing the highest quality mold products, the KF7300/5A is designed with roller LM guideways for high rigidity and enhanced acc/ deceleration.

Grease Lubrication Method

Significant cost savings is achieved by incorporating the grease lubrication system versus the oil lubrication method.



Rapid Traverse Rate (X/Y/Z) (B/C)

40/40/40 m/min **25/30** rpm

Travel (X/Y/Z)

765/650/520 mm (29.5"/25.6"/20.5")

SPINDLE & TABLE

Excellent machining performance with high-precision spindle & table

KF7300/5A Spindle Specifications

[] : Option

Speed r/min	Motor (Max./Cont.)	Torque (Max./Cont.)	Driving Method
12,000 rpm	22/18.5 kW (29.5/25 HP)	204/119 N·m (150.5/87.8 lbf·ft)	Built-in
[20,000 rpm]	[22/18.5 kW (29.5/25 HP)]	[98/80 N·m (72.3/59 lbf·ft)]	

KF7300/5A Table Specifications

Table Size	Max. Load Capacity	Slope Angle	Rotation Angle	Min. Indexing Angle	Driving Method
Ø730 mm (Ø28.7") [Ø630 mm (Ø24.8")]	500 kg (1,102)	+120° ~ -20°	360°	0.001°	Gear

HIGH-PERFORMANCE SPINDLE & TABLE

SPINDLE

Built-in Spindle

The built-in spindle is designed to minimize vibration and heat, as well as deliver rapid acc/ deceleration. Stable precision is maintained even under high speed and heavy duty operations.

Ram Type Spindle

The main shaft of KF7300/5A is a ram-type application, which minimizes the weight of the transported body and greatly improves the dynamic performance.

Spindle Cooling

The spindle cooling system minimizes thermal displacement which can happen during lengthy machining operations, and offers continued accuracy based on the thermal stability.

Through Spindle Coolant (20/30/70 bar) **OPTION**

Through Spindle Coolant is exceedingly useful when drilling deep holes. It helps increase the lifetime of the tool, while decreasing cycle time.



Dual Contact Spindle

The Big Plus spindle system (BBT40) provides dual contact between the spindle face and the flange face of the tool holder.

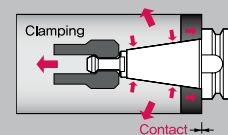

TABLE

5-axis Tilting Rotary Table Standard Application

The rotary table allows users to produce a wide range of complicated work pieces. It is possible to clamp each axis for extra rigidity and accuracy when machining.

- B-axis + support bearing structure (One-side drive type)
- Belt drive : Minimize backlash (Reducer not used)

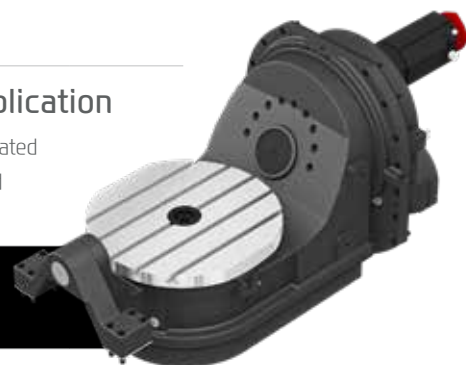

<B/C axis rotary scale standard application>

03 ATC & MAGAZINE

High Productivity Achieved with High Rigidity, Accuracy Machining

ATC Specifications

[] : Option

Model	No. of Tools	Max. Tool Length	Max. Tool Dia. (W.T/W.O)	Max. Tool Weight	Tool Shank
KF3500/5A	30 [40, 60] EA	270 mm (10.6")	30T : $\varnothing 80/125$ mm ($\varnothing 3.1"/\varnothing 4.9"$) [40, 60T : $\varnothing 76/125$ mm ($\varnothing 3"/\varnothing 4.9"$)]	8 kg (18 lb)	BBT40
KF7300/5A	40 [60] EA	300 mm (11.8")	$\varnothing 76/125$ mm ($\varnothing 3"/\varnothing 4.9"$) [60T : $\varnothing 75/127$ mm ($\varnothing 3"/\varnothing 5"$)]		BBT40 [HSK-A63]

HIGH RIGIDITY, TOOL CHANGE SYSTEM

ATC & MAGAZINE

High Speed ATC

Position control through twin arm ATC on servo motors has been improved drastically. In addition, tool exchanging has become easier, reducing specific cutting time tremendously.

Position control on the Twin Arm ATC has improved drastically. The twin arm ATC enables faster tool change and increased productivity.



Tool Change Time (C-C)

KF3500/5A : 3.4 sec KF7300/5A : 5.4 sec

Magazine

The tool magazine holds **30 tools** as standard and **60 tools** as an option. Due to the wider selection of tools and the random tool selection method, tool change time has improved.
(KF4600 II : Opt. 40 tools)

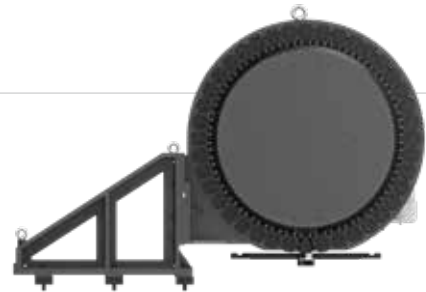

HSK TOOL HOLDER (KF7300/5A)

OPTION

HSK tool holder is utilized for precise positioning with less expansion in the spindle taper during high speed rotation. This ensures an excellent level of precision for die mold machining.



HSK-A63

04 USER CONVENIENCE

Various Devices for User Friendly

CHIP DISPOSAL SOLUTION & COOLANT UNIT

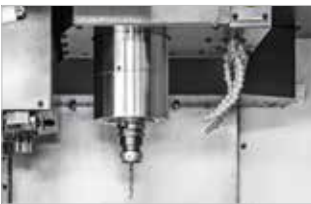

Cutting Air Blow (Opt.)



Bed Flushing Coolant (Opt.)



Gun Coolant (Opt.)



Air Gun (Opt.)

Upper-type Conveyor (KF3500/5A)

The upper type chip conveyor is applied as a standard to efficiently remove chips generated during machining.



Hinge	Chip Type : Roughing Chip, Long Chip, Chip complex	Material : SS41, 45C, Cast Steel	Side/Rear Direction
	Highly efficient when disposing a lot of chips. Capable of handling stringy chips..		
Scraper	Chip Type : Finely broken chip blown out	Material : cast Iron, Nonferrous	
	Convenient for shortly cut chips.		
❖ Screw	Chip Type : The lower portion of micro-chips	Material : Steel, Casting	
	Compresses and ejects chips to reduce chip Trouble.		
❖ Drum Filter	Chip Type : Powder, Micro Chip	Material : AL	
	Advantageous in precision, as the chips do not flow in to the coolant nozzle.		

❖ When ordering a screw or drum filter chip conveyor, prior consult with hyundai wia's sales person.

PRECISION SYSTEM



Linear Scale



Touch Sensor



TLM (Laser & Touch)

Optional

KF7300/5A + AWC (Automatic Workpiece Changer)



- Optimal Accessibility to Automation
- Configurable from □320mm-10 Pallets to □500mm-4 Pallets
- Applicable to workpieces up to 250 kg
(Pneumatic Chuck : Max. 250 kg)
- Telescopic 2-stage ARM Structure (Max St. 2,000 mm)



Workpiece Size	No. of Table
□ 320 (□ 12.6")×H350 mm (H13.8")	10 EA
□ 350 (□ 13.8")×H350 mm (H13.8")	8 EA
□ 400 (□ 15.7")×H350 mm (H13.8")	6 EA
□ 500 (□ 19.7")×H350 mm (H13.8")	4 EA



05 HYUNDAI WIA FANUC – SMART PLUS

The Compatible All-round Control



15" Touch-type Monitor as a standard

Smart Machine Control	Fast Cycle Time Technology
Conversational Program	Fine Surface Technology
i-HMI	Smart Guide-i
AI Contour Control	Machining-aid Function
Smooth Tolerance Control	AICC-2 (200 blocks)
JERK Control	0.1 μ m command and specify tolerance
Machining Condition Selection	Diminished vibration by controlling acceleration speed
Machining Quality Control Function	Designated machining level based on speed & quality
Part Program Storage	Smooth Tolerance+ integrated support
No. of Registerable Programs	5120M (2MB)
	1000 EA

MMS (Machine Monitoring System)



MMS Cloud

A cloud server-based equipment monitoring system for collecting and analyzing facility operation data.

Manufacturing big data solution with design, manufacturing, and intelligence technology of HYUNDAI-WIA (Big data collection/Analysis/Visualization)

SMART CNC (FANUC Smart Plus)



1. Dialogue Program (Smart Guide-i)

This software offers the maximum user convenience through dialogue manipulation from setup to processing. This includes writing processing programs and simulation checks.

2. LAUNCHER

This software offers shortcuts for quick access to specialized features and frequently used features.

SPECIFICATIONS

Standard & Optional

		KF3500/5A
Spindle		
12,000rpm (18.5kW)	Direct	●
12,000rpm (18.5kW)	Direct	○
20,000rpm (22kW)	Built-in	○
Spindle Cooling System		●
ATC		
ATC Extension	30	●
	40	○
	60	○
Tool Shank Type	BBT40	●
	BCV40	○
U-Center	D'andrea	-
Pull Stud	45°	●
Table & Column		
T-Slot Table		●
NC Rotary Table	Built-in	●
Coolant System		
Std. Coolant (Main Spindle Nozzle)		●
* Through Spindle Coolant	20bar	○
	30bar, 20 ℓ (5.3 gal)	○
	70bar, 15 ℓ (4 gal)	○
	70bar, 30 ℓ (7.9 gal)	○
Top Cover		●
Shower Coolant		○
Gun Coolant		○
Bed Flushing Coolant		○
Air Gun		○
Cutting Air Blow		○
Tool Measuring Air Blow (Only for TLM)		○
Chip Disposal		
Coolant Tank	365 ℓ (96.4 gal)	●
Interior Screw Chip Conveyor		●
Upper Chip Conveyor (Hinge)	Left	○
	right	○
Screw Type Chip Conveyor	Left	☆
	right	☆
Drum Filter Type Chip Conveyor	Left	☆
	right	☆
	rear	☆
Chip Wagon	Standard (180 ℓ)	○
	Swing (200 ℓ)	○
	Large Swing (290 ℓ)	○
	Large Size (330 ℓ)	○
	Customized	☆
S/W		
Dialogue Program (HW-DPRO)		○ (3+2 axis support)
DNC software (HW-eDNC)		○
Machine Monitoring System (HW-MMS Cloud)		☆
Smart Guide-i : FA/UC		●
Smart S/W		☆
Thermal Displacement Compensation Device		○

● : Standard ○ : Option ☆ : Prior Consultation - : Non Applicable

		KF3500/5A
Electric Device		
Call Light	1 Color : ●	●
Call Light & Buzzer	3 Color : ● ● ● B	○
Electric Cabinet Light		○
Remote MPG		●
3 Axis MPG		○
Work Counter	Digital	○
Total Counter	Digital	○
Tool Counter	Digital	○
Multi Tool Counter	Digital	☆
Electric Circuit Breaker		○
Transformer	30kVA	○
Auto Power Off		●
Back up Module for Black out		○
Measuring Device		
Air Zero	TACO	-
	SMC	-
Work Measuring Device		○
TLM	TLM	○
	Laser	-
Tool Broken Detective Device		-
Linear Scale	X/Y/Z Axis	○
Rotary Scale	A/C	●
Coolant Level Sensor (Bladder Type)		☆
Environment		
Air Conditioner		○
Oil Mist Collector		☆
Oil Skimmer (Only for Chip Conveyor)		○
MQL (Minimal Quantity Lubrication)		☆
Fixture & Automation		
Auto Door		○
Auto Shutter (Only for Automatic System)		-
Sub O/P		☆
External M Code 4EA		○
Automation Interface		☆
I/O Extension (In & Out)	16 Contact	☆
	32 Contact	☆
AWC (Automatic Workpiece Changer)		-
Hyd. Device		
Standard Hyd. Unit	70bar/15 ℓ	●
Central Hyd. supply	6 port, Max. 70bar	○
Hyd. Unit for Fixture	Customized	☆
ETC		
Tool Box		●
Customized Color	Need for Munsel No.	☆
CAD&CAM Software		☆

*1 : Please check the filter types with sales representative.

Specifications are subject to change without notice for improvement. / Please refer to the S/W catalog (IRIS) for details by S/W product.

SPECIFICATIONS

Standard & Optional

● : Standard ○ : Option ☆ : Prior Consultation - : Non Applicable

		KF7300/5A
Spindle		
12,000rpm (22kW)	Built-in	●
20,000rpm (22kW)	Built-in	○
Spindle Cooling System		●
ATC		
ATC Extension	40	●
	60	○
Tool Shank Type	BBT40	●
	HSK-A63	○
	BCV40	○
U-Center	D'andrea	☆
Pull Stud	45°	●
Table & Column		
Table Size	Ø630 (Ø24.8")	○
	Ø730 (Ø28.7")	●
T-Slot Table		●
NC Rotary Table	Gear	●
	DDM	-
Coolant System		
Std. Coolant (Main Spindle Nozzle)		●
* Through Spindle Coolant	20bar	○
	30bar	○
	70bar	○
Top Cover		●
Shower Coolant		○
Gun Coolant		○
Bed Flushing Coolant		○
Air Gun		○
Cutting Air Blow		○
Tool Measuring Air Blow (Only for TLM)		○
Air Blow for Automation		☆
Thru MQL Device (Without MQL)		☆
Coolant chiller (Sub Tank)		☆
Power Coolant System (For Automation)		☆
Chip Disposal		
Coolant Tank	340 ℓ (89.8 gal)	●
Interior Screw Chip Conveyor		-
Chip Conveyor (Hinge/Scraper)	Left	○
	right	☆
	rear	☆
Special Chip Conveyor (Drum Filter)		☆
Chip Wagon	Standard (180 ℓ)	○
	Swing (200 ℓ)	○
	Large Swing (290 ℓ)	○
	Large Size (330 ℓ)	○
	Customized	☆
S/W		
Dialogue Program (HW-DPRO)		○ (3+2 axis support)
DNC software (HW-eDNC)		○
Machine Monitoring System (HW-MMS Cloud)		☆
Smart Guide-i : FANUC		○
Smart S/W		☆

		KF7300/5A
Electric Device		
Call Light	1 Color : ●	●
Call Light & Buzzer	3 Color : ● ● ● B	○
Work Light		●
Electric Cabinet Light		○
Remote MPG		●
3 Axis MPG		○
Work Counter	Digital	○
Total Counter	Digital	○
Tool Counter	Digital	○
Multi Tool Counter	Digital	☆
Electric Circuit Breaker		○
Transformer	30kVA	○
Auto Power Off		○
Back up Module for Black out		○
Measuring Device		
Air Zero	TACO	○
	SMC	○
Work Measuring Device		○
TLM	TLM	●
	Laser	○
Tool Broken Detecting Device		☆
Linear Scale	X/Y/Z Axis	○
Rotary Scale	B/C Axis	●
Coolant Level Sensor (Bladder Type)		☆
Environment		
Air Conditioner		○
Eco-friendly energy (hydraulic device/chip conveyor saving mode)		○
Dehumidifier		○
Oil Skimmer (Only for Chip Conveyor)		○
MQL (Minimal Quantity Lubrication)		☆
Fixture & Automation		
Auto Door		○
Auto Shutter (Only for Automatic System)		○
Sub O/P		☆
NC rotary Table/F	Single	-
	Channel	-
Control of Additional Axis	1 Axis	-
	2 Axis	☆
External M Code 4EA		○
Automation Interface		☆
I/O Extension (In & Out)	16 Contact	☆
	8 Contact	☆
AWC (Automatic Workpiece Changer)		☆
Hyd. Device		
Std. Hyd. Unit	70bar/4 ℓ	●
Center Type Hyd. Supply Unit 2x2(Hydraulic : 4port) + Air 2port		○
Fixture Hyd. Unit	50bar	☆
	Customized	☆
ETC		
Tool Box		●
Customized Color	Need for Munsel No.	☆
CAD&CAM Software		☆

*1 : Please check the filter types with sales representative.

Specifications are subject to change without notice for improvement. / Please refer to the S/W catalog (iRIS) for details by S/W product.

SPECIFICATIONS

Spindle Output/Torque Diagram

KF3500/5A Direct 12,000rpm

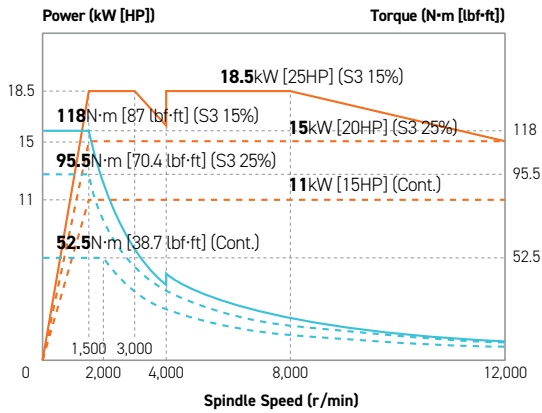

KF3500/5A Direct 15,000rpm

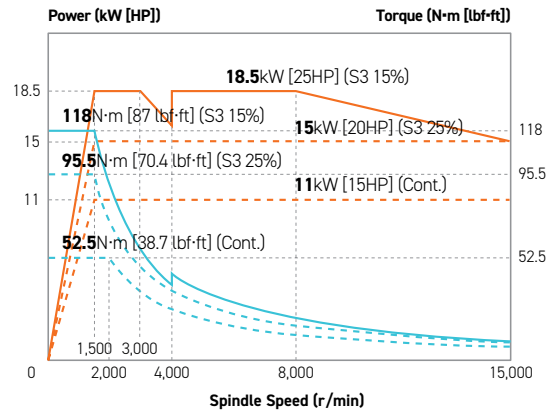

KF7300/5A Built-in 12,000rpm

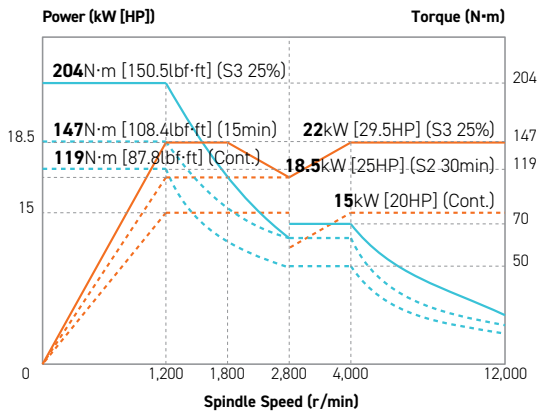

Built-in 20,000rpm

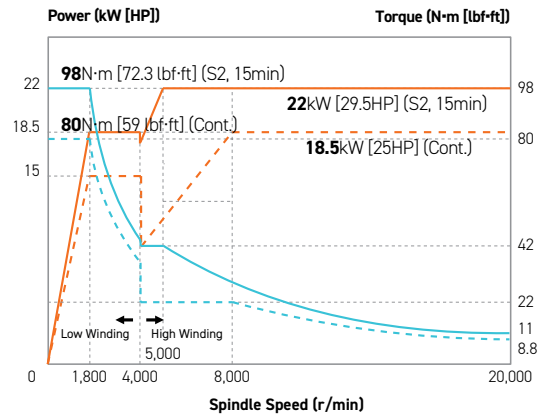

SPECIFICATIONS

External Dimensions

unit : mm(in)

KF3500/5A

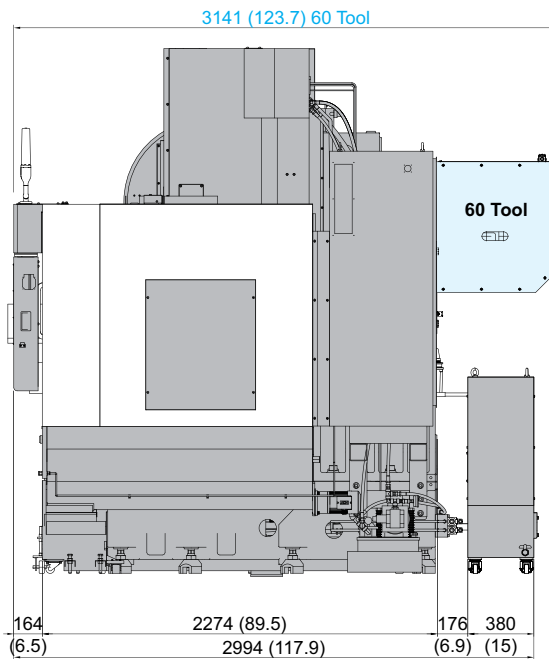
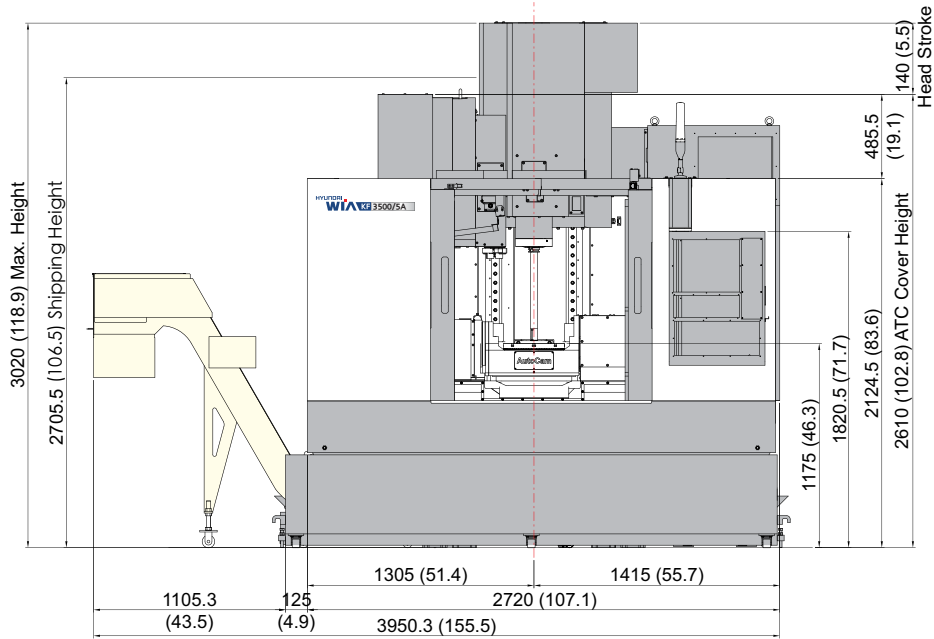

*Level Block Height : Upper Chip Conveyor (Side)_80mm (3.1")

ITEM	Max. Height	30T ATC Cover	40T ATC Cover	60T ATC Cover	Z-axis Motor	Head Cover
Upper/Side	3,020 (118.9)	2,610 (102.8)	2,816 (110.9)	2,411 (94.9)	2,705.5 (106.5)	2,636 (103.8)

SPECIFICATIONS

External Dimensions

unit : mm(in)

KF7300/5A

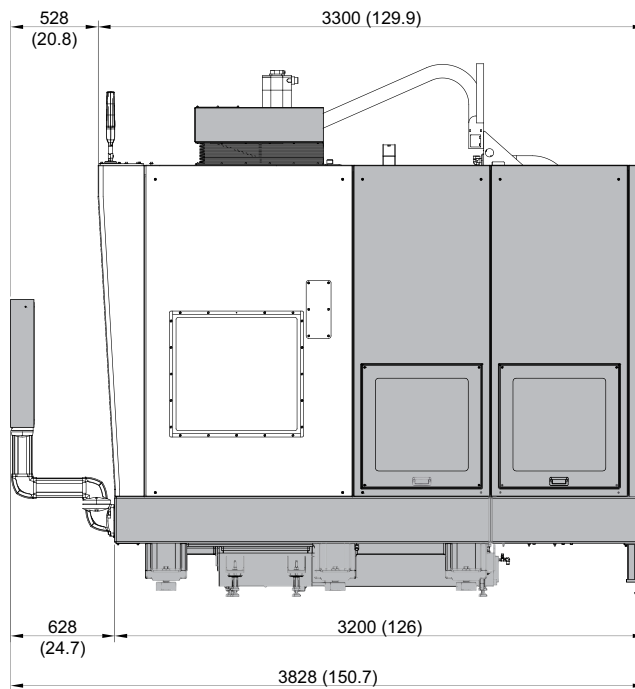
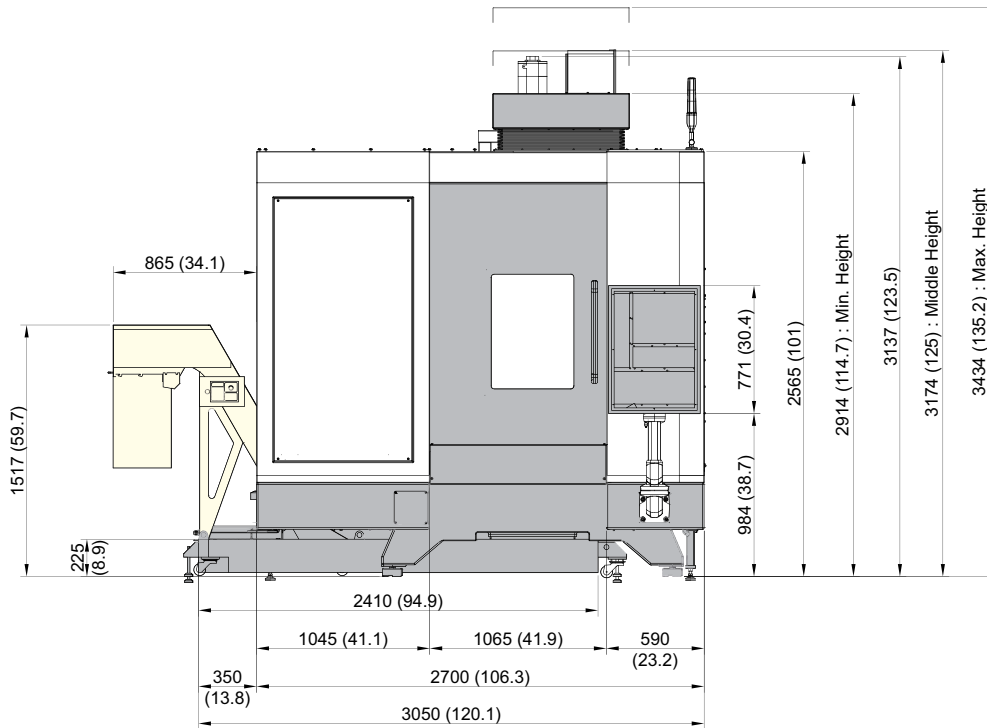

SPECIFICATIONS

External Dimensions

unit : mm(in)

KF7300/5A+AWC

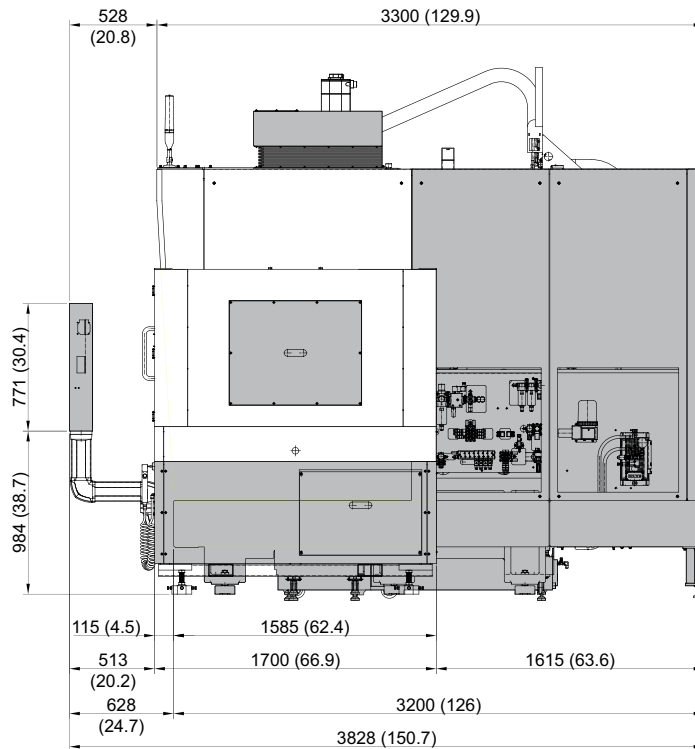
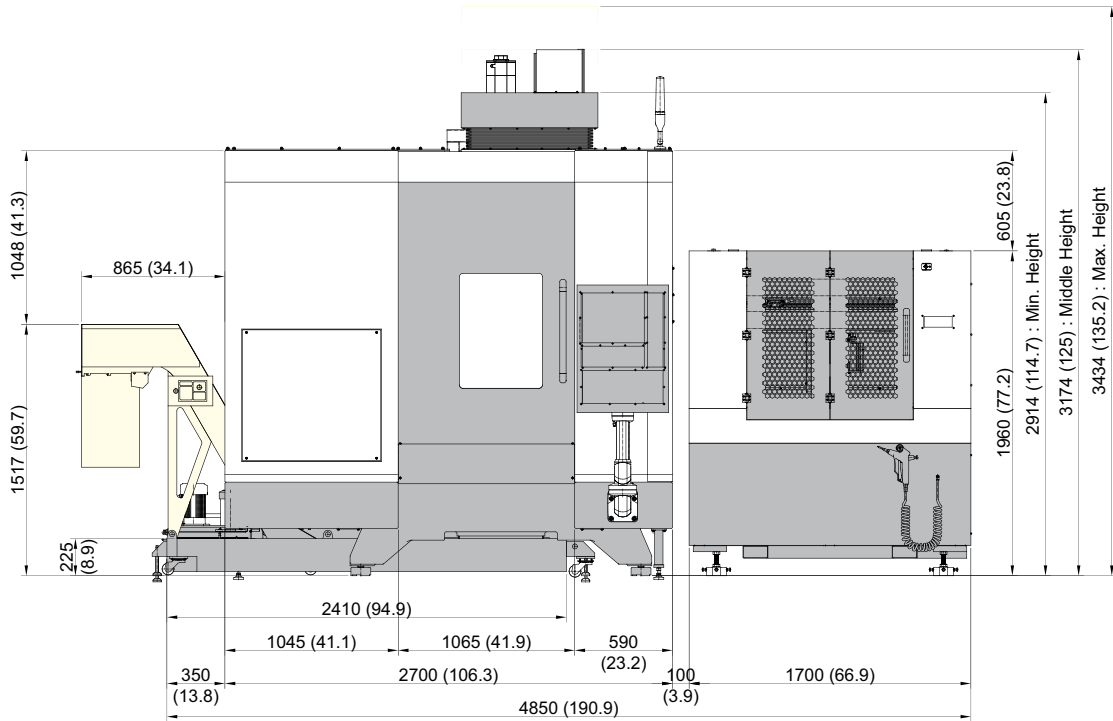

SPECIFICATIONS

Tool Shank

unit : mm(in)

BT40/BBT40, BIG PLUS

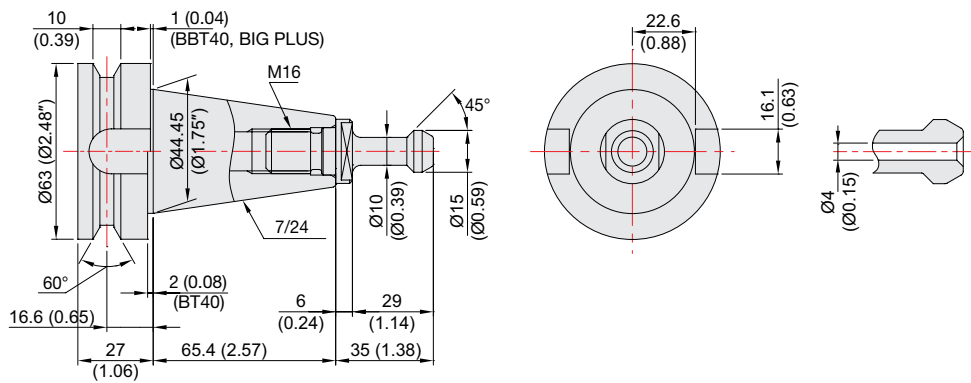

HSK A-63

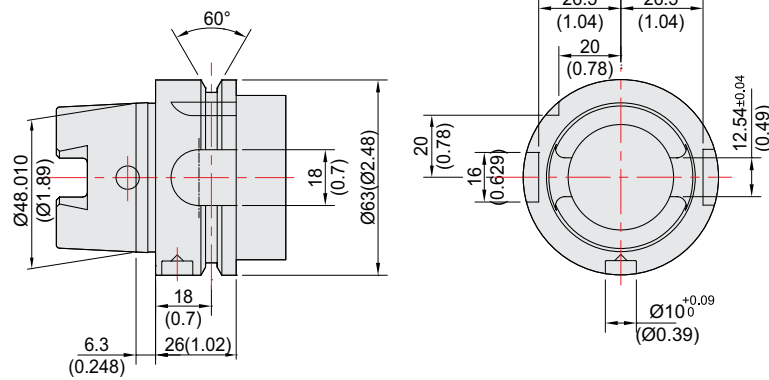

CAT40/BCV40

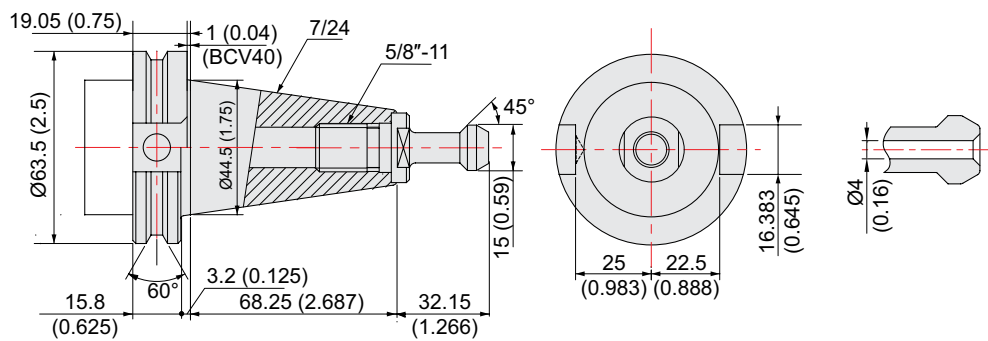

SPECIFICATIONS

Table Dimensions

unit : mm(in)

KF3500/5A

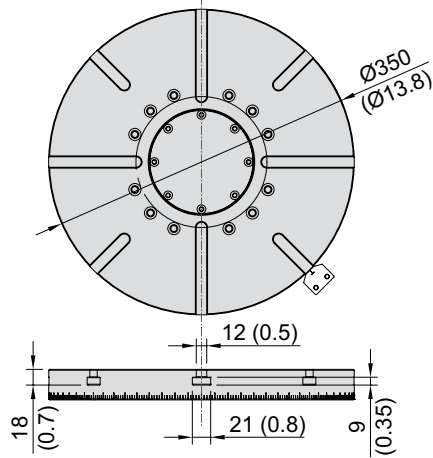

KF7300/5A
(Std. : Ø730)

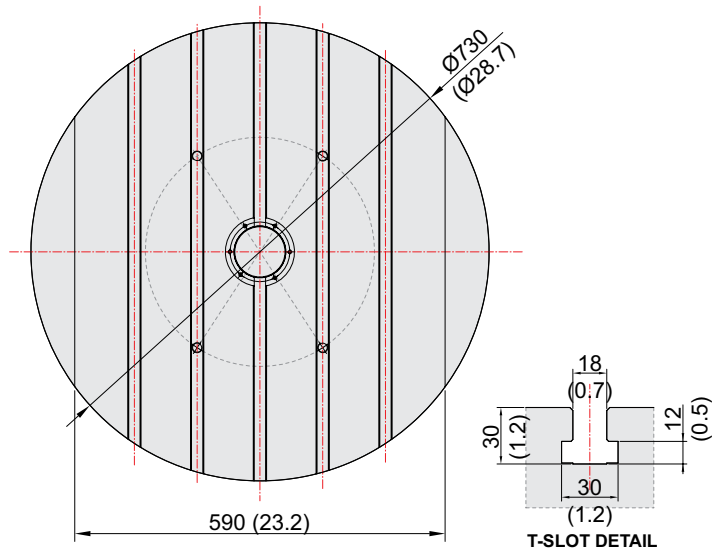

KF7300/5A
(Opt. : Ø630)

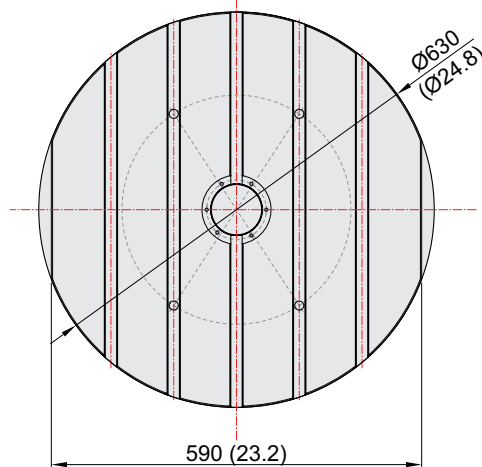

SPECIFICATIONS

Work Interference

unit : mm(in)

KF3500/5A

Tilting : A-axis 0°

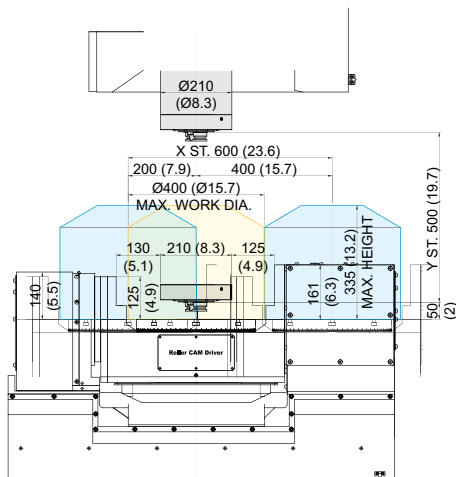

Tilting : A-axis -90°

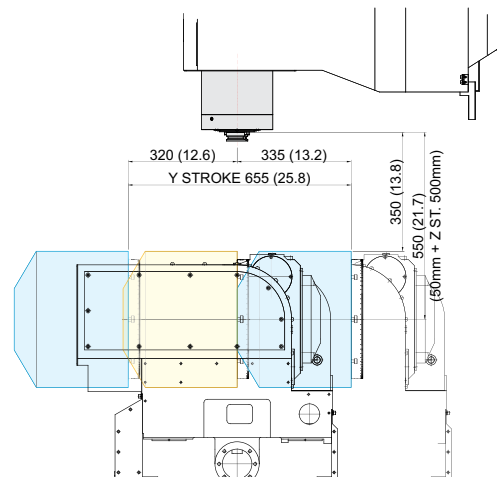

Tilting : A-axis -120°

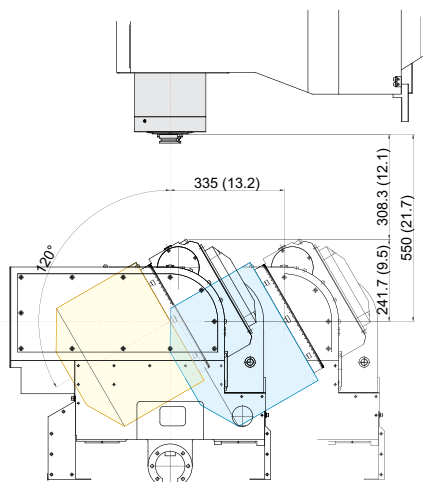

Tilting : A-axis +30°

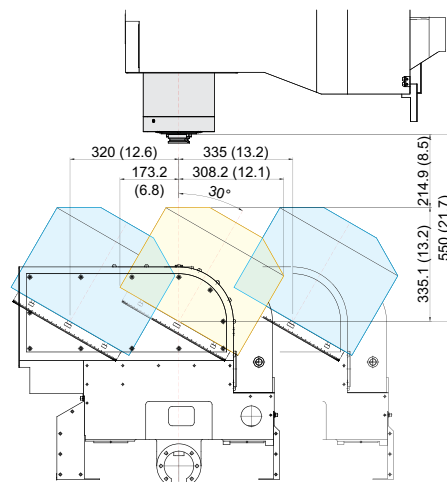

SPECIFICATIONS

Work Interference

unit : mm(in)

KF7300/5A

Tilting : B-axis 0°

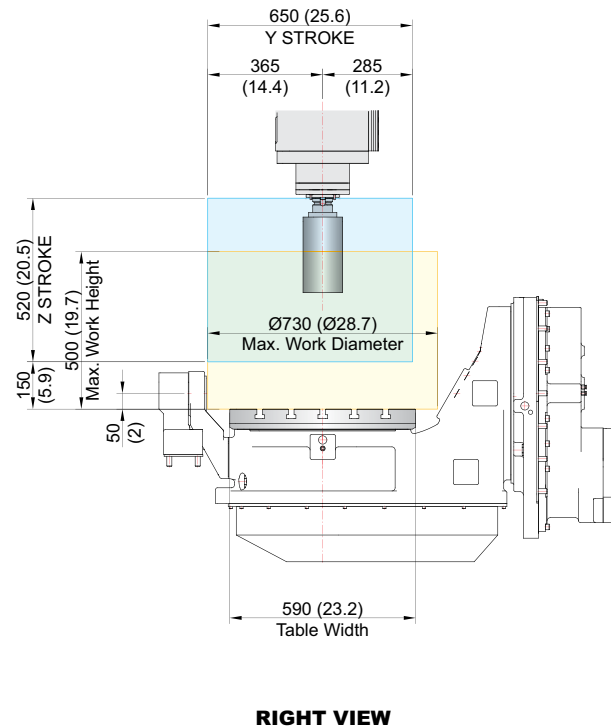
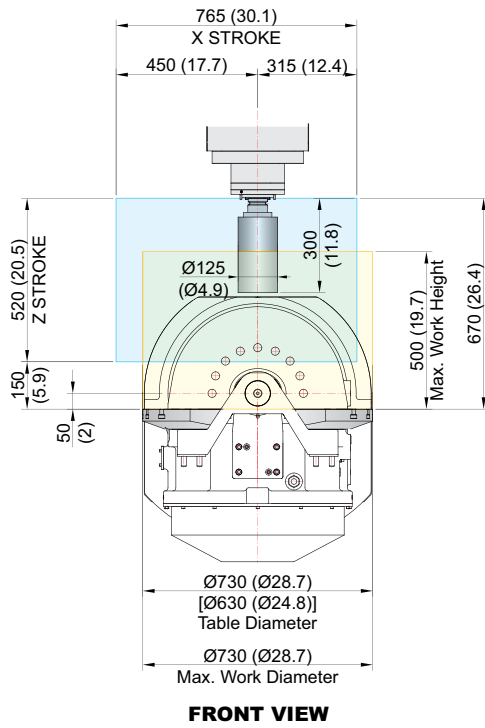

Tilting : B-axis 120°

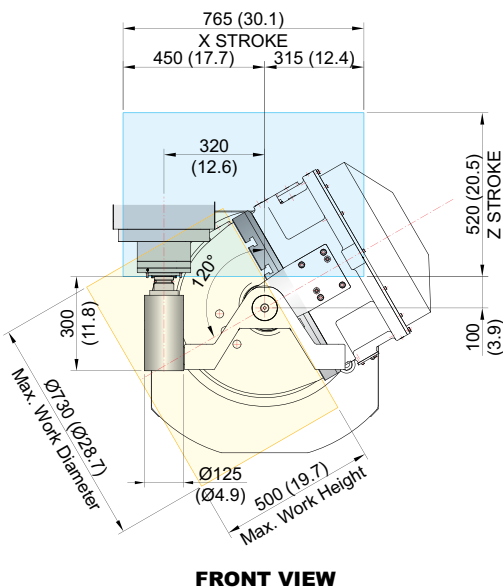

Tilting : B-axis 90°

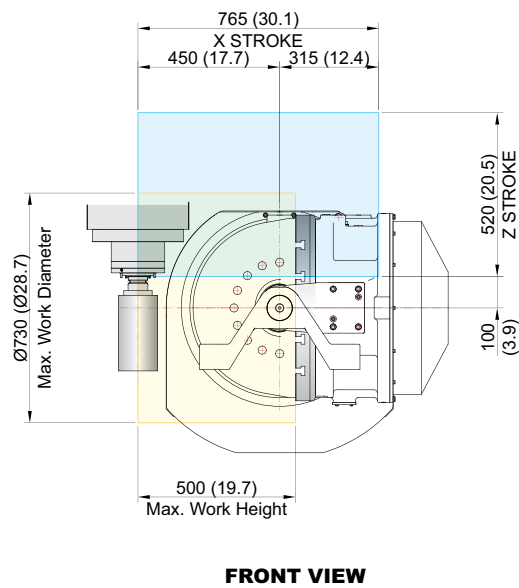

SPECIFICATIONS

Specifications

[] : Option

ITEM			KF3500/5A	KF7300/5A	
TABLE	Table Size (L×W)	mm(in)	Ø350 (Ø13.8")	Ø730 (Ø28.7") [Ø630 (Ø24.8")]	
	Max. Working Size (L×H)	mm(in)	Ø400×335 (Ø15.7"×13.2")	Ø730×500 (Ø28.7"×19.7")	
	Max. Load Capacity	kg(lb)	250 (551) - Max. Inertia : 2.09 kg.m ²	500 (1,102)	
	Table Driving Method	-	Roller Gear Cam	Gear	
SPINDLE	Spindle Taper	-	BBT40	BBT40 [HSK-A63]	
	Spindle Speed (rpm)	r/min	12,000 [15,000] [20,000]	12,000 [20,000]	
	Spindle Power (Max./Cont.)	kW(HP)	18.5/11 (25/15) [18.5/11 (25/15)] [22/18.5 (30/25)]	22/18.5 (30/25) [22/18.5 (30/25)]	
	Spindle Torque (Max./Cont.)	N·m(lbf·ft)	118/52.5 (87/38.7) [118/52.5 (87/38.7)] [98/80 (72.3/59)]	207/119 (152.7/87.8) [98/80 (72.3/59)]	
	Spindle Driving Method	-	Direct [Direct] [Built-in]	Built-in	
FEED	Travel	X/Y/Z	mm	400(+200)/655/500 (15.7"(+7.9")/25.8"/19.7")	765/650/520 (29.5"/25.6"/20.5")
		A(B)/C	deg	150°(+120°~-30°)/360°	
	Distance from Table Top to SP. Nose	mm(in)	50~500 (2"~19.7")	150 ~ 670 (5.9"~26.4")	
	Rapid Traverse Rate	X/Y/Z	m/min(ipm)	36/36/30 (1,417/1,417/1,181)	40/40/40 (1,575/1,575/1,575)
		A(B)/C	r/min	30/40	25/30
Slide Type	-	Roller Guide			
ATC	Tool Shank	-	BBT40	BBT40 [HSK-A63]	
	Number of Tools	ea	30 [40, 60]	40 [60]	
	Max. Tool Dia. (W.T/W.O)	mm(in)	Ø80/Ø125 (Ø3.1"/Ø4.9") [Ø76/Ø125 (Ø3"/Ø4.9")]	Ø76/Ø125 (Ø3"/Ø4.9") [Ø75/Ø127 (Ø3"/Ø5")]	
	Max. Tool Length	mm(in)	Ø76/Ø80 : 270 (10.6"), Ø125 : 210 (8.3")	300 (11.8")	
	Max. Tool Weight	kg(lb)	8 (17.6)		
	Tool Selection Method	-	Random		
	Tool Change Time (C-C)	sec	3.4	5.4	
TANK CAPACITY	Coolant Tank	ℓ(gal)	365 (96.4)	340 (89.8)	
	Lubricating Tank	ℓ(gal)	4 (1.1)	0.7 (0.18)	
	Hydraulic Tank	ℓ(gal)	15 (4)	4 (1.1)	
POWER SUPPLY	Air Consumption (0.5MPa)	ℓ/min(gal)	110 (29)	575 (151.9)	
	Electric Power Supply	KVA	26	43	
	Thickness of Power Cable	mm ²	Over 25	Over 35	
	Voltage	V/Hz	220/60 (200/50*)		
MACHINE	Floor Space (L×W)	mm(in)	2,845×2,274 (112"×89.5")	3,050×3,300 (120.1"×129.9")	
	Height	mm(in)	3,020 (118.9")	3,174 (125")	
	Weight	kg(lb)	8,000 (17,637)	11,500 (25,353)	
NC	Controller	-	H/WIA FANUC i Series - Smart Plus [FANUC 31i-B5 Plus]	FANUC 31i-B5	

*) Using 50Hz voltage instead of 60Hz may lower the output of motors. (excluding servo motors and inverter motors)
Specifications are subject to change without notice for improvement.

CONTROLLER

HYUNDAI WIA FANUC i Series – SMART PLUS : KF3500/5A

[] : Option ☆ Needed technical consultation

Controlled axis / Display / Accuracy Compensation	
Control axis	3 axis (X, Y, Z) [4 axis (X, Y, Z, A)] [5 axis (X, Y, Z, A, C)]
Simultaneously controlled axis	3 axis [Max. 4 axis]
Least setting Unit	X, Y, Z axis : 0.001 mm (0.0001 inch) B axis : 1 deg [0.001] deg
Least input increment	X, Y, Z axis : 0.001 mm (0.0001 inch) B axis : 1 deg [0.001] deg
Inch / Metric conversion	
High response vector control	
Interlock	All axis / Each axis
Machine lock	All axis
Backlash compensation	± 0 ~ 9999 pulses (Rapid traverse / Cutting feed)
Position switch	
LCD / MDI	15 inch LCD unit (with Touch Panel)
Feedback	Absolute motor feedback
Stored stroke check 1	Over travel
Stored stroke check 2, 3	
Stored pitch error compensation	
Operation	
Automatic operation (Memory)	
MDI operation	
DNC operation	Needed DNC software / CF card
Program restart	
Wrong operation prevention	
Program check function	Dry run, Program check, Z axis Machine lock Stored limit check before move
Single block	
Search function	Program Number / Sequence Number
Handle interruption	
Interpolation functions	
Nano interpolation	
Positioning	G00
Linear interpolation	G01
Circular interpolation	G02, G03
Exact stop mode	Single : G09, Continuous : G61
Dwell	G04, 0 ~ 9999.9999 sec
Skip	G31
Reference position return	1st reference, G28 / 2nd reference, G30 Ref. position check, G27
Single direction positioning	G60
Thread synchronous cutting	G33
Helical interpolation	Circular + Linear 2 axis (Max.)
Feed function / Acc. & Dec. control	
Manual feed	Rapid traverse Jog : 0~2,000mm/min (79 ipm) Manual handle : x1, x10, x100 pulses Reference position return
Cutting Feed command	Direct input F code
Feedrate override	0 ~ 200% (10% Unit)
Rapid traverse override	1%, 25%, 50%, 100%
Override cancel	
Feed per minute	G94
Feed per revolution	G95
Cylindrical interpolation	G07.1
Inverse time feed	G93
Look-ahead block	200 blocks (AI APC)
Program input	
Tape Code	EIA / ISO
Optional block skip	9 ea
Absolute / Incremental program	G90 / G91
Program stop / end	M00, M01 / M02, M30
Maximum command unit	± 999,999.999 mm (± 99,999.9999 inch)
Plane selection	X-Y, G17 / Z-X, G18 / Y-Z, G19
Workpiece coordinate system	G52, G53, 48 pairs (G54.1 P1 ~ 48)
Manual absolute	Fixed ON
Programmable data input	G10
Sub program call	10 folds nested
Custom macro	#100 ~ #199, #500 ~ #999
Programmable mirror image	G51.1, G50.1
G code preventing buffering	G4.1
Optional chamfering corner R	

Program input	
Polar coordinate command	G15, G16
Canned cycle	G73, G74, G76, G80 ~ G89
Scaling	G50, G51
Coordinate system rotation	G68, G69
Conversational Program	Smart Guide-i
Auxiliary function / Spindle speed function	
Level-up M Code	Multi / Bypass M code
Spindle speed function	S & S digit, Binary output
Spindle override	0% ~ 150% (10% Unit)
Spindle orientation	M19
Retraction for rigid tapping	
FSSB high speed rigid tapping	
Tool function / Tool compensation	
Tool function	Max. T8 digit
Tool life management	
Tool offset pairs	400 pairs
Tool nose / radius compensation	G40, G41, G42
Tool length offset	G43, G44, G49
Tool offset memory C	Tool geometry and wear (Cutter and tool length)
Tool length measurement	Z axe Input C
Editing function	
Part program storage size	5,120m (2MB)
No. of registerable programs	1,000 ea
Program protect	
Background editing	
Extended part program editing	Copy, move and change of NC program
Memory card program edit	
Data input / output & Interface	
I/O interface	CF card, USB memory Embedded Ethernet interface
Screen hard copy	
External message	
External key input	
External workpiece number search	
Automatic data backup	
Setting, display and diagnosis	
Self-diagnosis function	
History display & Operation	Alarm & Operator message & Operation
Run hour / Parts count display	
Maintenance information	
Actual cutting feedrate display	
Display of spindle speed / T code	
Graphic display	
Operating monitor screen	Spindle / Servo load etc.
Power consumption monitoring	Spindle & Servo
Spindle / Servo setting screen	
Multi language display	Support 24 languages
Display language switching	Selection of 5 optional Languages
LCD Screen Saver	Screen saver

Option	
Fast ethernet	Needed option board
Data server	Needed option board
Protection of data at 8 levels	
Additional Axis	
Manual handle feed	2/3 units #100 ~ #199, #500 ~ #999, #98000 ~ #98499
Add. Workpiece	Max. 300 pairs (G54.1 P1 ~ P300)
AICC II	400 blocks ☆

Figures in inch are converted from metric values.

The FANUC controller specifications are subject to change based on the policy of company CNC supplying.

CONTROLLER

FANUC 31i-B5 Plus : KF3500/5A

[] : Option ☆ Needed technical consultation

Controlled axis / Display / Accuracy Compensation	
Control axis	5 axis (X, Y, Z, A, C : KF3500/5A)
Simultaneously controlled axis	5 axis (X, Y, Z, A, C : KF3500/5A)
Least setting Unit	X, Y, Z axis : 0.001 mm (0.0001 inch) B axis : 1 deg [0.001] deg
Least input increment	X, Y, Z axis : 0.001 mm (0.0001 inch) B axis : 1 deg [0.001] deg
Inch / Metric conversion	G20 / G21
High response vector control	
Interlock	All axis / Each axis
Machine lock	All axis
Backlash compensation	± 0~9999 pulses (Rapid traverse / Cutting feed)
Position switch	
LCD / MDI	15" color LCD with Touch screen
Feedback	Absolute motor feedback
Stored stroke check 1	Over travel
Stored stroke check 2, 3	
Pitch error compensation	Interpolation Type
Operation	
Automatic operation (Memory)	
MDI operation	
DNC operation	Needed DNC software / CF card
Program restart	
Wrong operation prevention	
Program check function	Dry run, Program check Z axis Machine lock, Stroke check before move
Single block	
Search function	Program Number / Sequence Number
Handle interrupt	
3D Manual Feeding	
Retraction for rigid tapping	
Manual guide i	Smart Guide i
Interpolation functions	
Pano interpolation	G05.1
Positioning	G00
Linear interpolation	G01
Cylindrical interpolation (Including 3D)	G02, G03 (G02.4, G03.4)
Exact stop mode	Single : G09, Continuous : G61
One-way positioning	G60
Inverse-time feed	G93
Dwell	G04, 0 ~ 9999.9999 sec
Skip	G31
Reference position return	1st reference : G28 2, 3, 4 reference : G30 P2, P3, P4 Ref. position check : Z7
Thread synchronous cutting	G33
Helical interpolation	Circular + Linear interpolation 2 axis (max.)
Feed function / Acc. & Dec. control	
Manual feed	Rapid traverse Jog : 0~5,000mm/min (197 ipm) Manual handle : x1, x10, x100 pulses Reference position return
Cutting Feed command	Direct input F code
Feedrate override	0 ~ 200% (10% Unit)
Rapid traverse override	F0% (F1%), F25%, F50%, F100%
Override cancel	
Feed per minute	G94
Feed per revolution	G95
Look-ahead block	600 Block
Program input	
Tape Code	EIA / ISO
Optional block skip	9 ea
Absolute / Incremental program	G90 / G91
Program stop / end	M00, M01 / M02, M30
Maximum command unit	± 999,999.999 mm (± 99,999.9999 inch)
Plane selection	X-Y : G17 / Z-X : G18 / Y-Z : G19
Workpiece coordinate system	G52, G53, 48 pairs (G54.1 P1 ~ P48)
Manual absolute	Fixed ON
Programmable data input	G10
Sub program call	10 folds nested
Sub program call	10 folds nested

Controlled axis / Display / Accuracy Compensation	
Custom macro	#100~#199, #500~#599, #98000~#98499
G code system	A
Inclined surface command / Tool axis direction control	G68.2 / G53.1
Scaling	G50, G51
Programmable mirror image	G51.1, G50.1
Polar coordinate command	G15, G16
Do not look ahead function	G4.1
Including Chamfering / Corner R	
Canned cycle	G73, G74, G76, G80 ~ G89
Coordinate rotation	G68, G69
Auxiliary function / Spindle speed function	
Auxiliary function	M 4 digit
Level-up M Code	Multi / By-Pass
Spindle speed command	S 5 digit, Binary output
Spindle override	50% ~ 120% (10% Unit)
Spindle orientation	M19
FSSB high speed rigid tapping	
Tool function / Tool compensation	
Tool function	Max. T 8 digit
Tool life management	256 pairs ☆
Tool offset pairs	400 pairs
Tool nose radius compensation (Including 3D)	G40, G41, G42 (G41.2~6, G42.2~6)
Tool nose length compensation (With leading point control)	G43, G44, G49 (G43.4~5)
Tool offset memory C	Tool length, diameter, abrasion(length, diameter)
Tool length measurement	Z axis Input C
Editing function	
Part program storage size	10240m (4MB)
No. of registerable programs	1,000 ea
Program protect	
Background editing	
Extended part program editing	
Memory card program edit	Copy, move and change of PC program
Protection of data at 8 levels	
Data input / output & Interface	
I/O interface	Memory card, USB memory interface Embedded Ethernet interface
Screen hard copy	
External message	
External key input	
External workpiece number search	
Automatic data backup	
Setting, display and diagnosis	
Self-diagnosis function	
History display	Alarm & Operator message & Operation
Run hour / Parts count display	
Maintenance information	
Actual cutting feedrate display	
Display of spindle speed / T code	
Graphic display	
Operating monitor screen	
Power consumption monitoring	Spindle & Servo
Multi language display	Support 25 languages
Display language switching	Selection of 5 optional Languages
LCD Screen Saver	Screen saver
Macro Excutor	Custom software 8MB (WIA Screen)☆
Processing select	Speed/rigidity setting
Option	
Fast ethernet	Needed option board
Data server	Needed option board (1GB, 2G, 4GB)
Sub Spindle control	☆
Polar coordinate interpolation	G12.1, G13.1
Cylindrical interpolation	G07.1
Manual handle feed	2/3 units
Tool management function	
Tool offset number	499 ~ Max. 2,000 pair
Program storage capacity	~ 8MByte
Program registration number	Max. 4,000 ea
Additional work coordinate	300 pair (G54.1 P1 ~ P300)

Figures in inch are converted from metric values.

The FANUC controller specifications are subject to change based on the policy of company CNC supplying.

CONTROLLER

FANUC 31i-B5 : KF7300/5A

Axis control / Display unit	
Controlled axis	5 axis (X, Y, Z, B, C)
Simultaneous controllable axis	5 axis (X, Y, Z, B, C)
Least input increment	X, Y, Z axis : 0.001 mm (0.0001") A, C axis : 0.001"
Least command increment	X, Y, Z axis : 0.001 mm (0.0001") A, C axis : 0.001"
Inch / Metric conversion	G20 / G21
Interlock	Each axis / All axis
Machine lock	All axis
Stored stroke check 1	
Mirror image	
Follow-up	
Servo off	
Backlash compensation	+/- 0~9999 pulse (rapid traverse & cutting feed)
Position switch	
Stored pitch error compensation	
LCD/MDI	15" color LCD
Operation	
DNC operation by the memory card	
Program restart	
Program check function	Dry run, program check
Single block	
Feed functions	
Manual jog feed	Rapid, Jog, handle
Manual handle feed-rate	x1, x10, x100
Feedrate override	0~200% (10% Unit)
Jog feed	0~5,000mm/min (197ipm)
Rapid traverse override	F1, F25%, F50%, F100%
Override cancel	
Rapid traverse bell-shaped acceleration/ deceleration	
Auto corner override	
Program input & Interpolation functions	
Interpolation Function	Positioning/Linear/Circular (G00/G01/G02/G03)
Exact stop mode/Exact stop	G61 / G09
Dwell	G04, 0~9999.9999 sec
Helical interpolation	
Threading/synchronous feed	
Manual reference point return	
Reference point return	G28
Reference point return check	G27
2nd Reference point return	G30
Program stop/end	M00, M01 / M02, M30
Optional block skip	1 ea
Max. programmable dimensions	+/- 9999.9999" (+/- 8 digits)
Program number / Sequence number	O4 / P8 digit
Absolute/incremental command	G90 / G91
Plane selection	G17, G18, G19
Work coordinate preset	G52~G59
Manual absolute	"On" fixed
Programmable data input	G10
Sub program call	10 Step
Custom macro	
Circular interpolation	G02, G03
Canned cycle	G73, G74, G76, G80 ~ G89
Optional chamfering/corner R	
Skip function	G31
Automatic coordinate system setting	
Coordinate system rotation	G68, G69
Programmable mirror image	G50.1, G51.1
Bidirectional pitch error compensation	
AI contour control(AICC) II	200 Block

Sub / Spindle functions	
Miscellaneous function	M 4 digit
Spindle speed command	S 5 digits, binary output
Spindle speed override	50% ~ 120% (10% Unit)
Spindle orientation	
Rigid tapping	
Tool functions / Tool compensation	
Tool function	Max. T8 digits
Cutter compensation C	G40~G42
Tool length compensation	G43, G44, G49
Tool length measurement	Z axis INPUT C
Tool offset pairs	64 pair
Tool life management	
Data input / Output & Editing functions	
Input/output interface	Memory card
Embedded Ethernet	100 Mbps
Part program storage length	128 Kbyte (320m)
Registered programs	250 ea
Memory lock	
Back ground editing	
Extended part program editing	Copy, move, change of NC program
Setting, display, diagnosis	
Self-diagnosis function	
History display	Alarm & operator message
Run hour/Parts count display	
Actual cutting feedrate display	
Graphic display	
Spindle/Servo setting screen	
Multi-language display	Selection of 5 optional language
Screen Saver	
Auto Data Backup	

Option	
Additional work coordinate system	G54.1 P1~P48 (48 pair) G54.1 P1~P300 (300 pair)
Additional custom micro change	#100 ~ #199, #500 ~ #999
Work coordinate Command	G15, G16
Work coordinate Interpolation	G12.1, G13.1
Helical interpolation	G07.1
Single direction positioning	G60
Scaling	
Manual handle interrupt	
Additional optional Blockskip	9 ea
AI contour control(AICC) 1	200 Block/Select processing conditions/ Auto power off
AI contour control(AICC) 2	200 Block/Select processing conditions/ data server/Auto power off
AI contour control(AICC) 3	600 Block/Select processing conditions/ data server/Auto power off
AI contour control(AICC) 4	1000 Block/Select processing conditions/data server/Auto power off
Tool offset number	200 pair
Program registration number	Max. 1000 ea *(Note 1)
Part program storage length	~ 8Mbyte
Data server	1GB
High speed ethernet	100 Mbps
Manual Guide i	Interactive automatic program
Dynamic graphic display	
Tool load monitoring function	HWTM (Mounted)

*Note 1) The program registration number may vary depending on the part program storage capacity.



You  HYUNDAI WIA MT
www.youtube.com/HYUNDAIWIAMT

CREATING VALUE IN SEAMLESS MOBILITY

With its top-quality HYUNDAI WIA machine tool creates a new and better world.



<http://machine.hyundai-wia.com>
HYUNDAI WIA Machine Tools
Global Links

HEADQUARTER

R&D Center/Factory 153, Jeongdong-ro, Seongsan-gu, Changwon-si, Gyeongsangnam-do, Korea TEL : +82 55 280 9114 FAX : +82 55 282 9114

Overseas Sales Team /R&D Center 37, Cheoldobangmulgwan-ro, Uiwang-si, Gyeonggi-do, Korea TEL : +82 31 8090 2539

OVERSEAS OFFICES

HYUNDAI WIA Machine America corp. 450 Commerce Blvd, Carlstadt, NJ 07072, USA TEL : +1-201-987-7298

HYUNDAI WIA Europe GmbH Alexander-Fleming-Ring 57, 65428 Rüsselsheim Germany TEL : +49-0-6142-9256-0

HYUNDAI WIA Machine Tools China Company No.16 Fenghuang Road, Fenghuang Town, Zhangjiagang City, Jiangsu Province, China TEL : +86-21-6427-9885

India Branch Office #4/169, 1st Floor, LOTTE BLDG, Rajiv Gandhi Salai, (OMR), Kandanchavadi, Chennai - 600096, Tamilnadu, India TEL : +91-76-0490-3348